

# 6M12

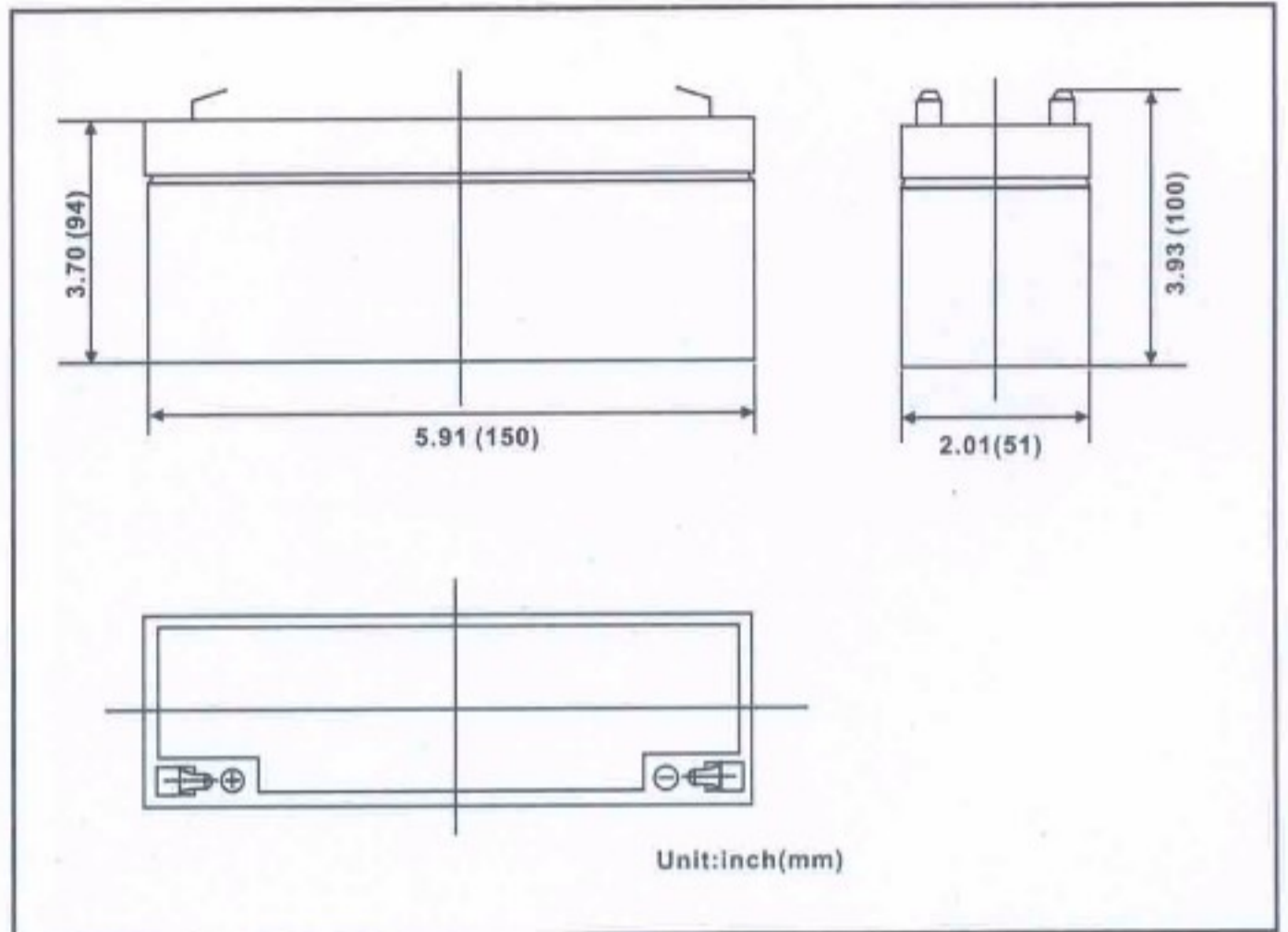

## SPECIFICATIONS

Nominal Voltage		6V			
Nominal Capacity		12Ah			
Dimensions	Length	5.91 inches(150mm)		Weight	Approx 4.26lbs (1920g)
	Width	2.01 inches(51mm)			
Dimensions	Height	3.70 inches(94mm)		Terminals	F3(standard)
	Total Height	3.93 inches(100mm)			F2(optional)
Capacity 77°F(25°C)	20 hour rate(600mA)	12.0 Ah	Constant Voltage Charge	Cycle	Initial Charging Current less than 3.6A Voltage 7.25-7.45V at 77°F(25°C)Temp.coefficient -15mv/°C
	10 hour rate(1120mA)	11.2 Ah			
	5 hour rate(1920mA)	9.6 Ah			
	1 hour rate(7750mA)	7.7 Ah			
	15 minute rate(18.48A)	4.6 Ah			
Capacity affected by Temperature	104°F(40°C)	102%	Standby	Initial Charging Current less than 3.6A Voltage 6.75-6.9V at 77°F(25°C)Temp.coefficient -10mv/°C	
	77°F(25°C)	100%			
	32°F(0°C)	85%			
	5°F(-15°C)	65%			
Internal Resistance	Full charged battery 77°F(25°C) < 12mΩ				

Discharge Characteristics @ 77°F(25°C)

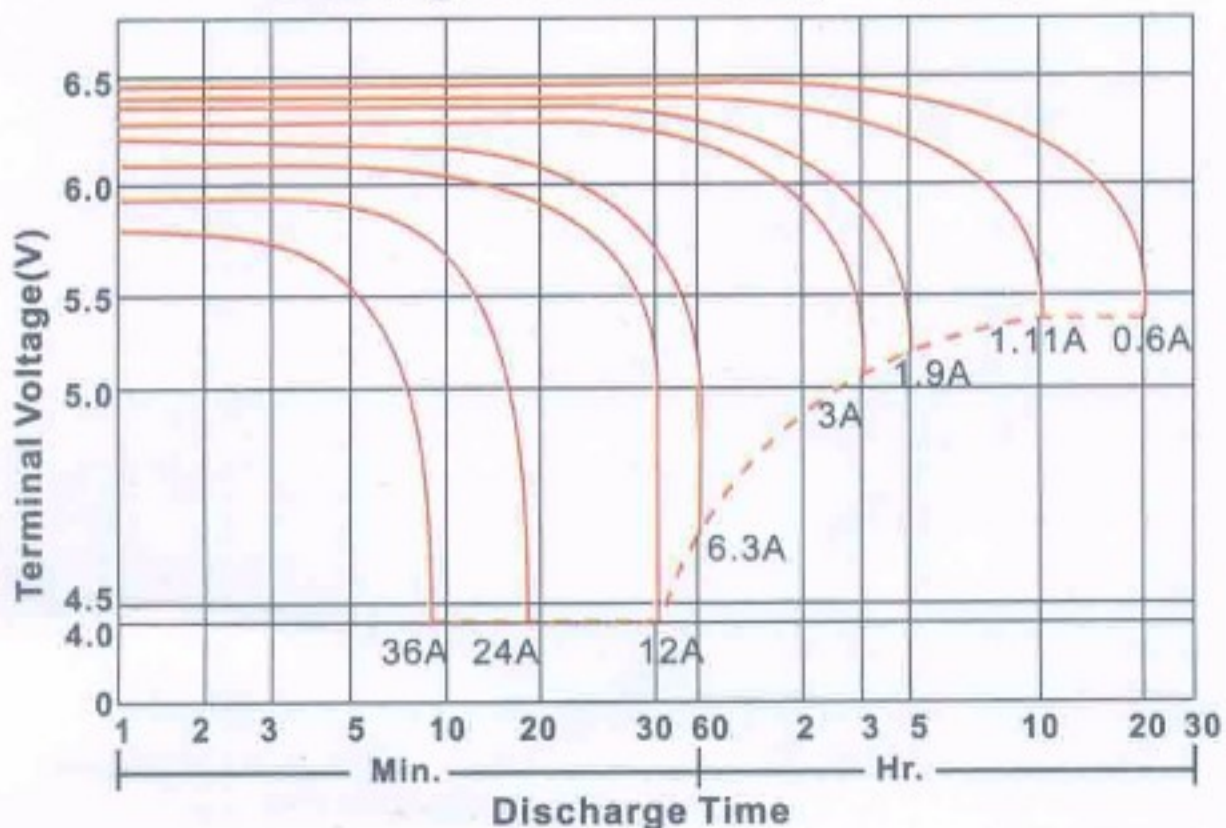

Discharge Time Vs. Discharge current

